

# REVOLVING CENTER STANDARD

(For Conventional Slow Speed  
Non CNC application.  
Not recommended for Heavy  
Duty Application)

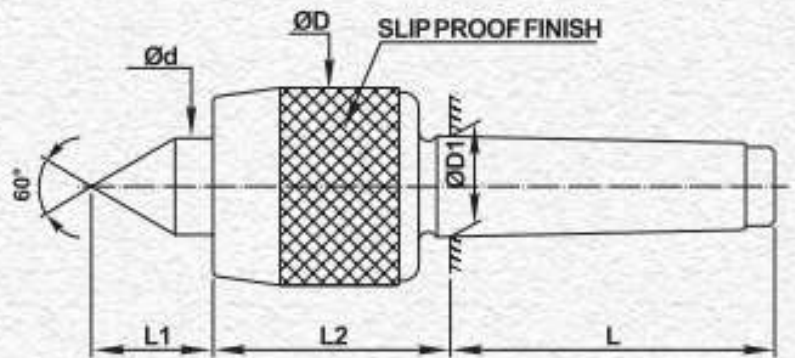

Part No.	Model	Shank Taper	Ød mm	ØD mm	ØD1 mm	L1 mm	L2 mm	L mm	Max. Job Wt. Kg.	Conc. Error mm
RC MT1 STD	Standard	MT-1	18.0	46.5	12.065	26.0	51.5	53.5	25	0.015
RC MT2 STD	Standard	MT-2	23.0	50.0	17.780	31.0	59.0	64.0	50	0.015
RC MT3 STD	Standard	MT-3	30.0	62.0	23.825	38.0	68.5	81.0	75	0.015
RC MT4 STD	Standard	MT-4	30.0	62.0	31.267	38.0	71.0	102.5	100	0.015
RC MT5 STD	Standard	MT-5	34.0	68.0	44.399	42.0	75.5	129.5	150	0.015
RC MT6 STD	Standard	MT-6	50.0	105.0	63.348	58.0	91.0	182.0	200	0.015

Also Available as Carbide Tipped & Female.